



Specification Data

Column & Boom Manipulators

Medium Duty Series

Range up to 4.0 x 4.0 metres

The **Red Rock** medium duty series of Column & Boom Manipulators are specifically designed and built to withstand the harsh and rugged environments expected in the welding industry. It includes the following features:

- A slewing ring for column mounting, thereby providing a smooth 360-degree lockable rotation.
- All vertical and horizontal rails are precisely machined in single runs giving unsurpassed smooth and steady travel.
- Latest Inverter drives fitted for variable speed of horizontal boom arm travel and rail travel car (optional).
- Worm gearbox for vertical travel via AC motor complete with brake for added safety.
- High tensile roller chain used for vertical travel with the addition of a counter balance system provides smooth effortless vertical travel.
- IP 55 control box and low voltage pendant control station.
- Standard safety feature includes anti-fall device and limit switches for all functions.
- Internally trunked cabling.

Inclusive:

- Power source mounting bracket of your choice

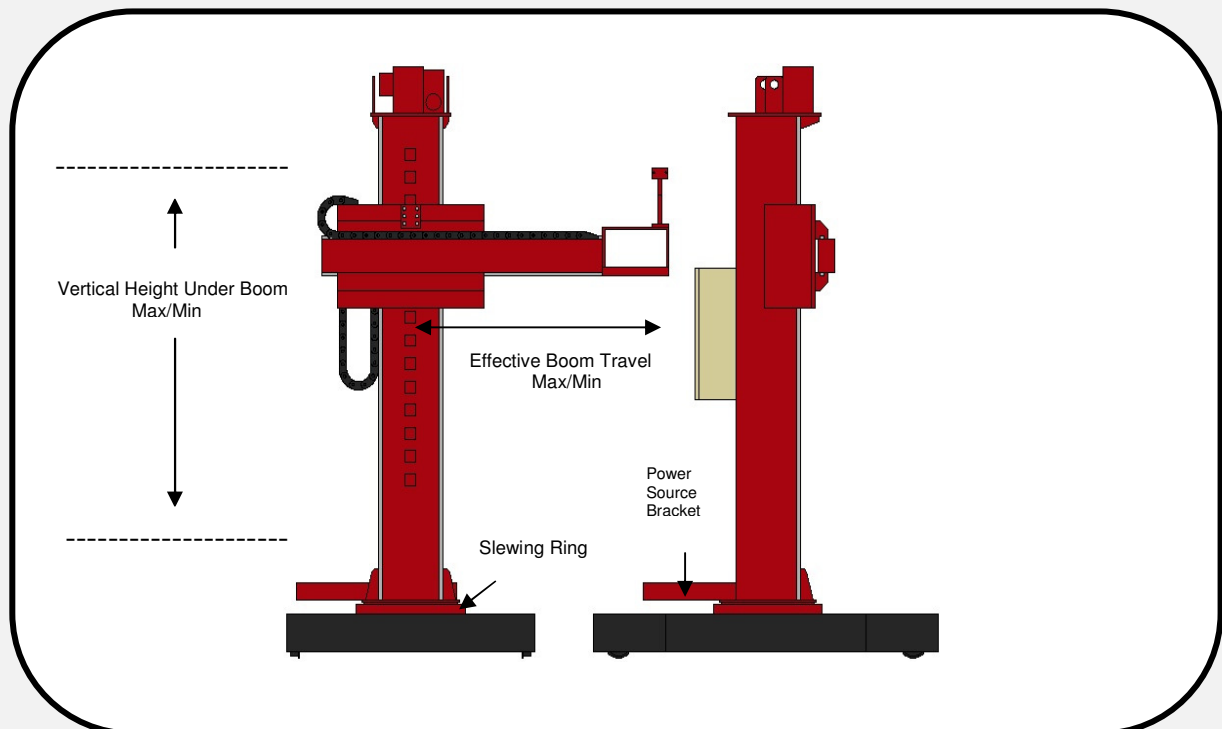



Specification Data
Column & Boom Manipulators
Medium Duty Series
Range up to 4.0 x 4.0 metres

Optional features includes

- Travel car, manual or motorized variable speed operated via the same pendant station via selector switch.
- X-Y slide, manual or motorized, operated via the same pendant station.
- Compressed air operated flux recovery unit
- Welding power source & wire feeder controller system

All Column & Boom Manipulators are grit blasted to SA2.5 and two coats of zinc phosphate paint followed by one coat of polyurethane paintwork will ensure that your investment provides you with many years of uninterrupted service.

Specification

Input Voltage: 3-Phase Voltage (Specify 3 –phase voltage requirement before ordering)			
Electrical Box: IP55 code			
Vertical Travel Speed: 750mm/min			
Boom Travel Speed: 200 to 2070 mm/min			
Carriage Travel Speed: 450 to 4500 mm/min (optional)			
Model	Effective Travel (Horizontal) mm	Height Under Boom (Vertical) mm	Overall Height (mm)
MM2525	2500	2500	3500
MM3030	3000	3000	4000
MM3535	3500	3500	4500
MM4040	4000	4000	5000

All dimensions are subject to change without prior notice.
 All speed base on 50Hz.
 Please advise welding power source/welding head to be use.



Specification Data
Column & Boom Manipulators
Medium Duty Series
Range up to 4.0 x 4.0 metres

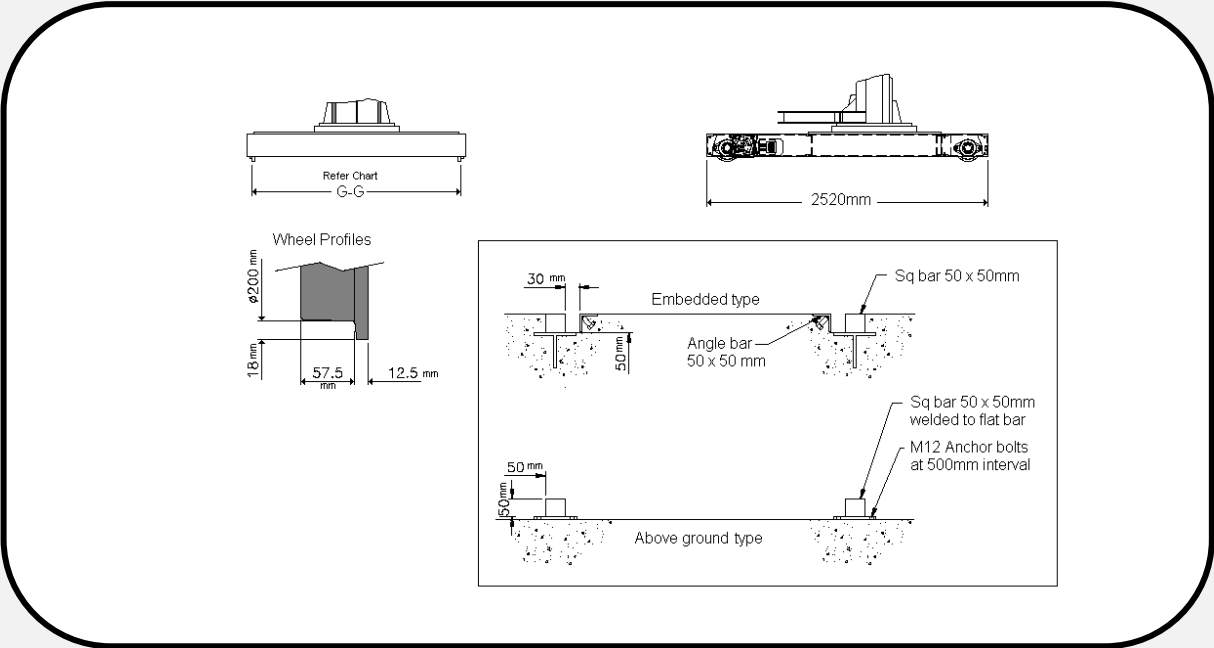

Manipulator Rail Gauge Table

Medium Duty Type Travelcar Rails G-G in mm (250kg Payload)

MM series

Boom Height	2	2.5	3	3.5	4
2	GG1650	GG2000	GG2500	GG2000	GG2500
2.5					
3					
3.5					
4					

Notes:
V denotes Max.Under Boom Height (Vertical), in hundreds of mm. i.e. 20 = 2000mm
H denotes Effective Boom Travel (Horizontal), in hundreds of mm. i.e. 20 = 2000mm



Specification Data
Column & Boom Manipulators
Medium Duty Series
Range up to 4.0 x 4.0 metres

Ordering Information Checklist

Equipment	Part Number	Description	
Column & Boom Manipulator	MM25/25 MM30/30 MM35/35 MM40/40	2.5 x 2.5-metre Column & Boom 3.0 x 3.0-metre Column & Boom 3.5 x 3.5-metre Column & Boom 4.0 x 4.0-metre Column & Boom (Comes with standard fixed Base unless specified)	
Base	Options	Fixed base (standard) for floor mounting Travel car Manual for rail mounting Travel car Motorized for rail mounting	Standard Optional Optional
Electrical Control	Options	Panel & 3-phase AC motor Panel, step-over & 3-phase AC motor	Standard Optional

Welding System Accessories

<p>Option One</p> <ul style="list-style-type: none"> Lincoln NA3s Controller K208A weld head Drive roll kit Wire reel 600 amps nozzle Cable kit Assemble 10-Metre ground Cable with clamp DC 1000 power source <p>Optional:</p> <p>Rotary Clamp 1000 amp</p>	<p>Option Two</p> <ul style="list-style-type: none"> Lincoln NA5 Controller K346A weld head Drive roll kit Wire reel 600 amps nozzle Cable kit Assemble 10 Metre ground Cable with clamp DC 1000 power source <p>Optional:</p> <p>Rotary Clamp 1000 amp</p>	<p>Option Three</p> <ul style="list-style-type: none"> Miller HDC 1500 Controller RAD Weld head Flux hopper Drive roll kit (Specify wire size) Wire straightener 600amps Nozzle Wire reel Cable kit assembly 10 Metre ground Cable with clamp Dimension 1000 power source <p>Optional:</p> <p>Rotary Clamp 100 amp</p>
--	---	--